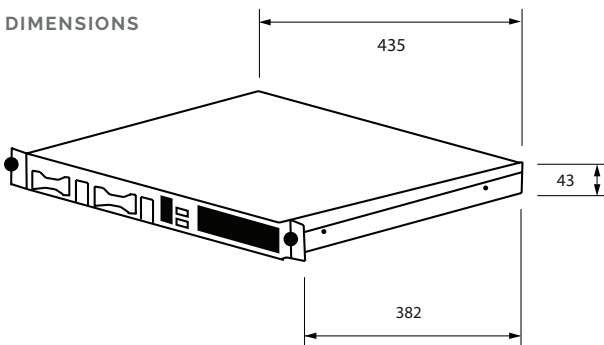

WEBserver 100

COLOUR

DIMENSIONS

SPECIFICATION

Dimensions / Weight	19" 1U, 434 × 382 × 43 mm / 10 kg
Mounting	RACK
Operation conditions	10–30 °C / RH 5–95 %, non-condensing
Power supply	230 VAC / 2 A / C14 connector
Ethernet	2 × 1 Gbps / RJ45
Serial	2 × USB 3.0
CPU	x64 6-core 3,4 GHz
RAM / Storage	16 GB / 2 × 1 TB RAID 1
OS / Platform	Linux / SSI framework
Order code	WEBserver-100-RACK
Package dimensions	670 × 580 × 260 mm
Storage conditions	5–35 °C / RH 5–95 %, non-condensing
Accessories in the package	power cable and rack mounting kit
Optional accessories	GSM, Wi-Fi
Certifications	CE, FCC, RoHS

WEBserver for Helvar is a compact solution for supervision and control of lighting in conjunction of Helvar router system. Allows end users and maintenance engineers to view, edit, control and report on many of the aspects of the lighting control system.

WEBserver is a highly scalable solution that consists of hardware and software modules. This model allows you to add additional features after purchase and installation.



WEBserver-100-RACK is a hardware designed for big- size projects, **limited up to 100 Helvar Routers**.

KEY FEATURES

Powered by SSI Framework

Bundled compact solution Hardware + Software



Quick discovery of Helvarnet

User management with configurable permissions

SOFTWARE MODULES AND ACCESSORIES

Custom lighting system visualization

- Online creation and editing via Web browser
- An effective time-saving tool
- Order code: **Vizual-5H** or **Vizual-20H**

Energy monitoring

- Archiving energy data for 8/32 Groups
- Data Analytics - Day / Week / Month chart
- Quick compare of consumption
- Order code: **Energy-8G** or **Energy-32G**

Integration with other systems

- BACnet server for easy browsing with BMS
- Order code: **BACnet-1000** or **BACnet-5000**
- RESTful API
- Additional modules for connecting other devices
- BACnet client: **BACnet-5D** or **BACnet-20D**
- Modbus Master: **Modbus-5D** or **Modbus-20D**
- Mbus Master: **Mbus-5D** or **Mbus-20D**

Scheduler

- User entries can be automated via Scheduler
- Monthly / Weekly / Daily View over the planned events
- Support of Emergency Tests Scheduling
- Order code: **Planner-8E** or **Planner-32E**

Reporting

- Alarm console for remote system diagnostics
- Emergency lighting reports and test history
- Periodically sends energy report via e-mail
- Order code: **Reporter**

Remote access and services

- Remote Access for 1 technician or user for 12 months
- Decrease of traveling time and cost
- Effective system maintenance and remote services
- Order codes for extensions and accessories: **Remote-Access**, **Remote-WiFi**, **Remote-GSM**, **Remote-1U**, **Remote-12M**